

Place SAM 01 profile block on side spindle 2.
 Place SAM 01 profile block on side spindle 3.
 Place SAM 28 profile block on the first top spindle.

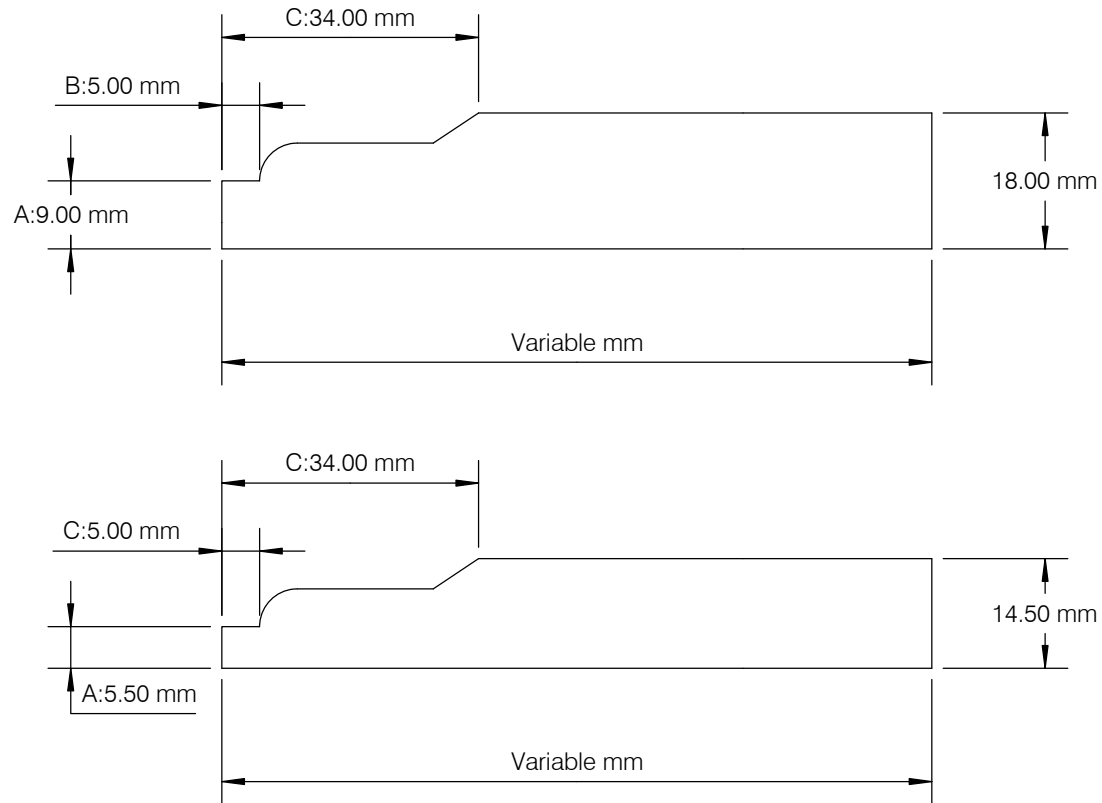

PRINTED COPY UNCONTROLLED

Double version of this profile is SAM 4938

AREA MACHINED AWAY: 154.37 SQMM

MOULDER	ANY
PASSES	1
DRAWN BY	S McMaster
DATE	24/06/2019
SCALE	1:1
REV:	1
AUTH:	TOLERANCE +/- 0.5MM



Newpark Industrial Estate
 Greystone Road, Antrim
 BT41 2RU
 T: +44 (0)28 9442 8288 F: +44 (0)28 9442 8244
 E: team@samonline.co.uk
 W: www.samonline.co.uk

PROFILE
SAM 28